

# T-Shirt Press

## Instructions:

Materials	Time (Seconds)	Temperature (Fahrenheit Degree)
Pure Cotton	25-30s	360-430
Polyester	25s	360-430
Pearl Board	10-15s	300-360
Key Chain	40s	430-450
Mouse Pad	25-30s	360-430
PVC Board	40s	360

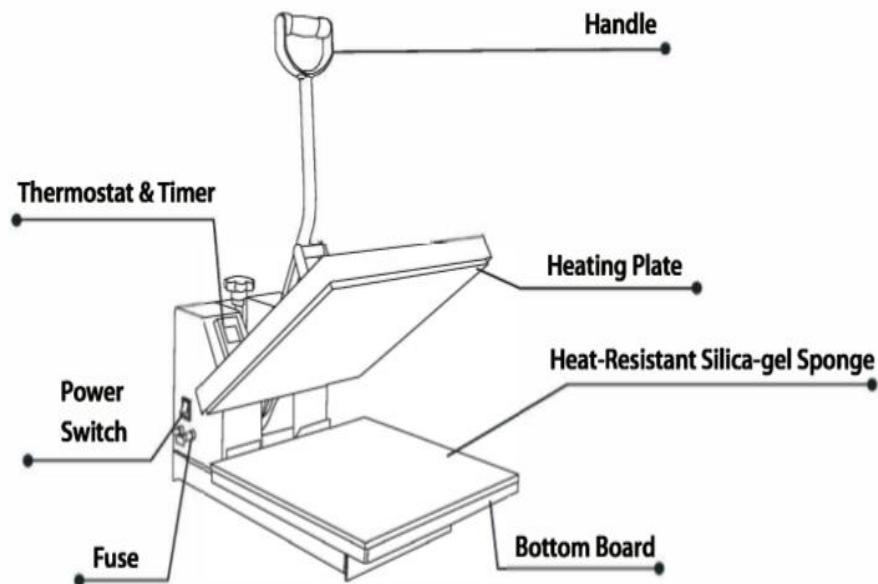

① Turn on the heat press by pressing the power switch into the ON position. Open the panel (otherwise the machine will utter "beep" sound as a reminder).

(Refer to Image 6)

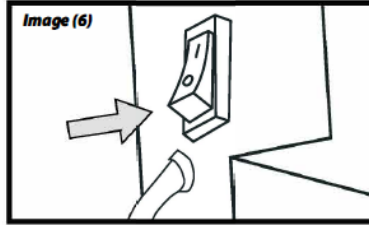

② Set the target temperature: Press the "TEMP" button, then press the up or down arrow (^ or v) to set the desired temperature; Then press the "TEMP" button again to lock it in.

(Refer to Image 7)

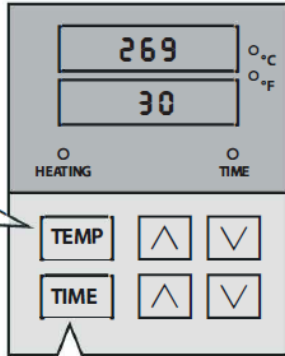

③ Set the target time: Press the "TIME" button, then press the up or down arrow (^ or v) to set the required time and press the "TIME" button again to lock it in.

(Refer to Image 7)

④ Wait till the heat press heats to the target temperature.

⑤ Close the panel, pre-heat the silicone pad for about 30 seconds

⑥ Open the panel, place your garment (with image) on the bottom platen/ silicone pad so that it is flat and there are no wrinkles in the material. The garment should be set evenly across the surface.

Press the TEMP/TIME button to return to the initial interface.

⑦ Proceed by closing the handle downward into the locked position.

⑧ Open the handle when automatic timer buzzes.

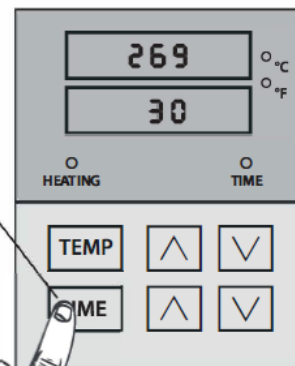

Image (7)

